

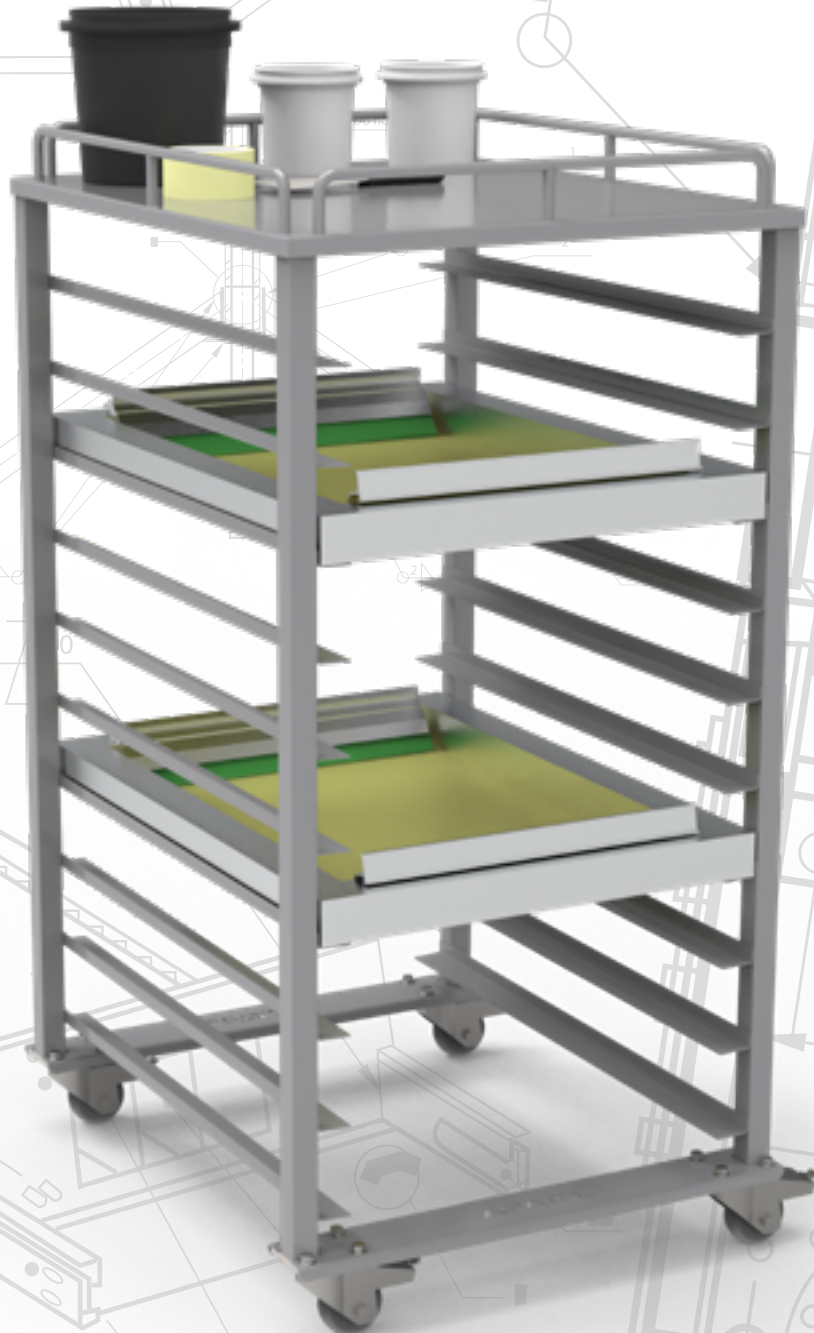

ANATOL

INK CART

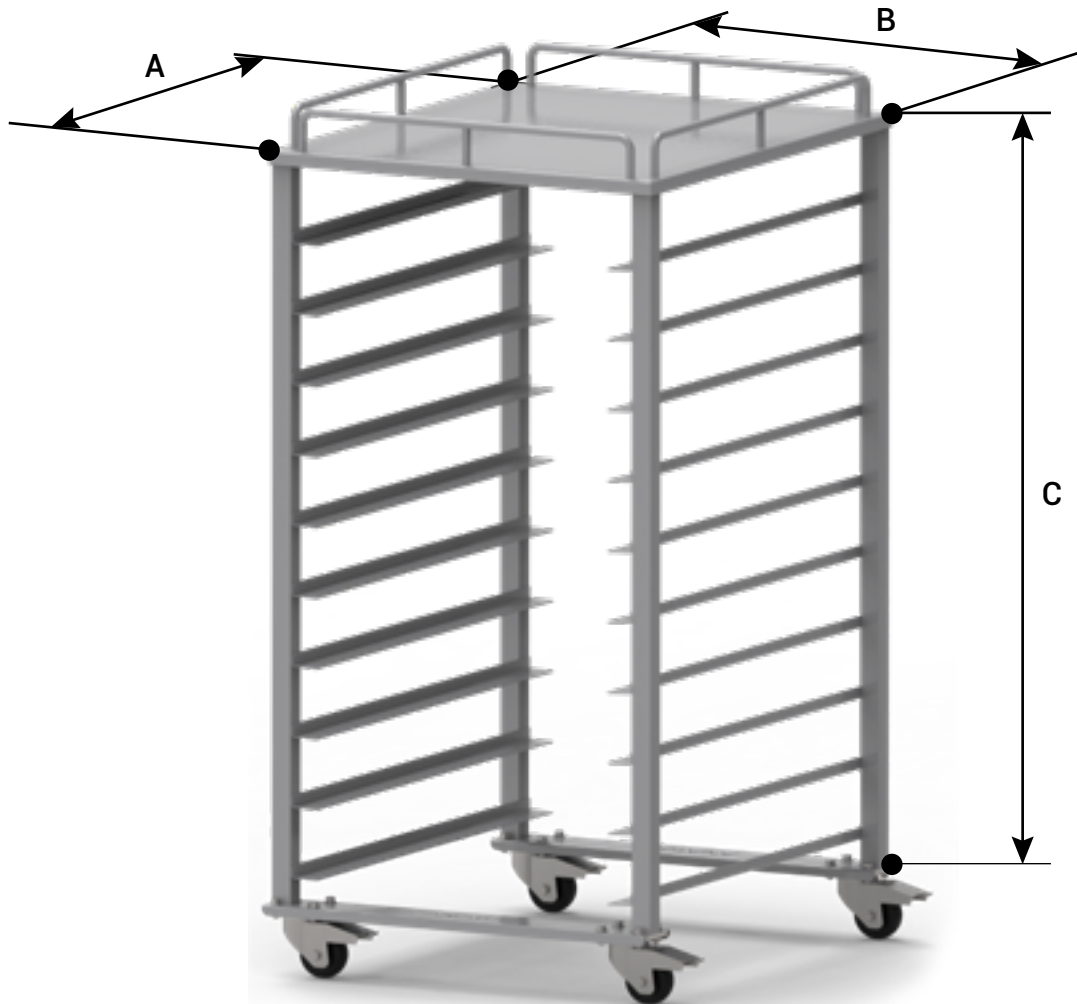



	A	B	C
21"x28"	23.6" 600mm	29.8" 758mm	45" 1144mm
23"x33"	25.7" 653mm	34.8" 886mm	45" 1144mm
26"x36"	28.6" 728mm	37.8" 962mm	45" 1144mm
26"x43"	28.6" 728mm	44.8" 1139mm	45" 1144mm

COMPONENTS

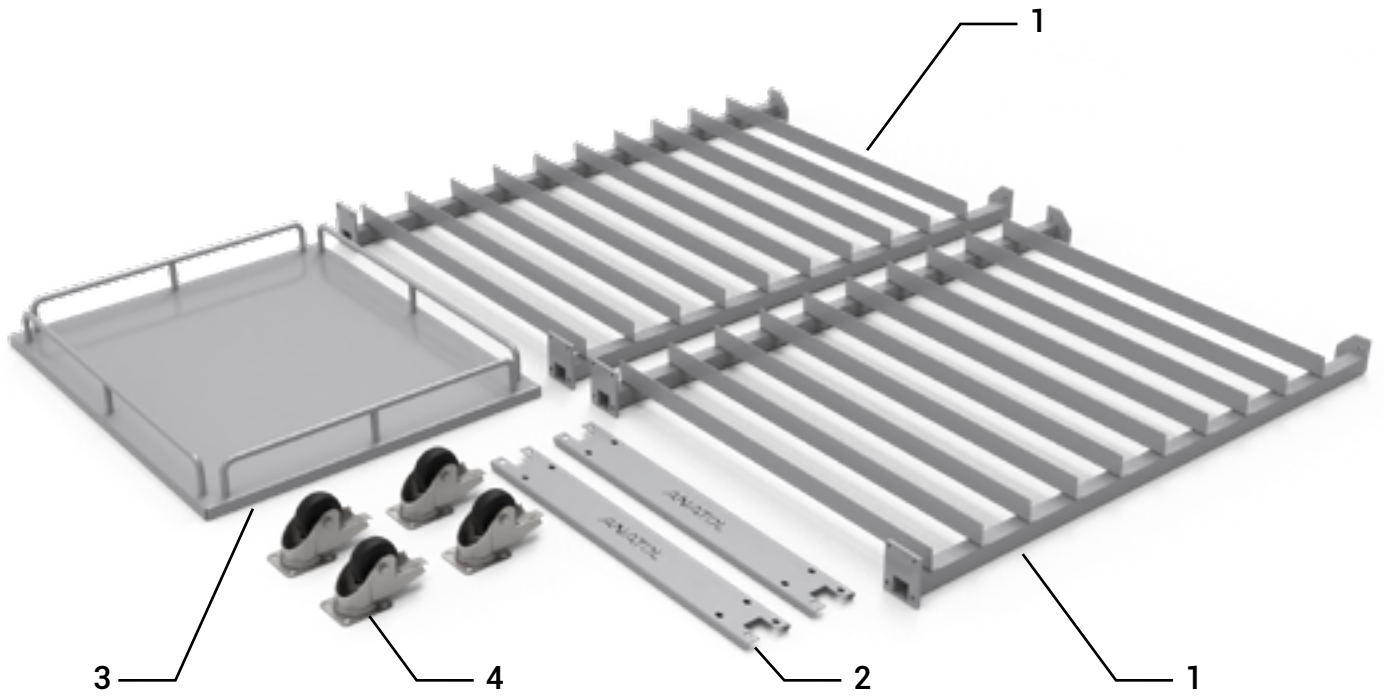

1. Shelf wall - 2 pcs.

2. Lower crossbars - 2 pcs.

3. Upper lid - 1 pcs.

4. Wheels - 4 pcs.

5. Bolts M8x20 - 16 pcs.

6. Nut M8 - 16 pcs.

7. Bolts M6x20 - e 12 pcs.

8. Washer 7.4 - 12 pcs.

9. Washer small 8.4 - 16 pcs.

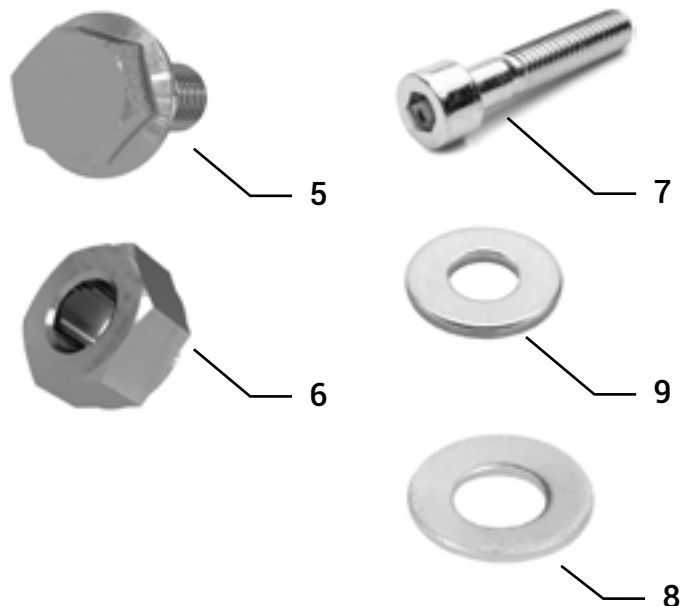

1. Place the upper lid (3) on the shelf walls (1) as shown in Figure 1 first by fixing the upper lid barriers in the center and attach them using the bolts (7) and washer (8)

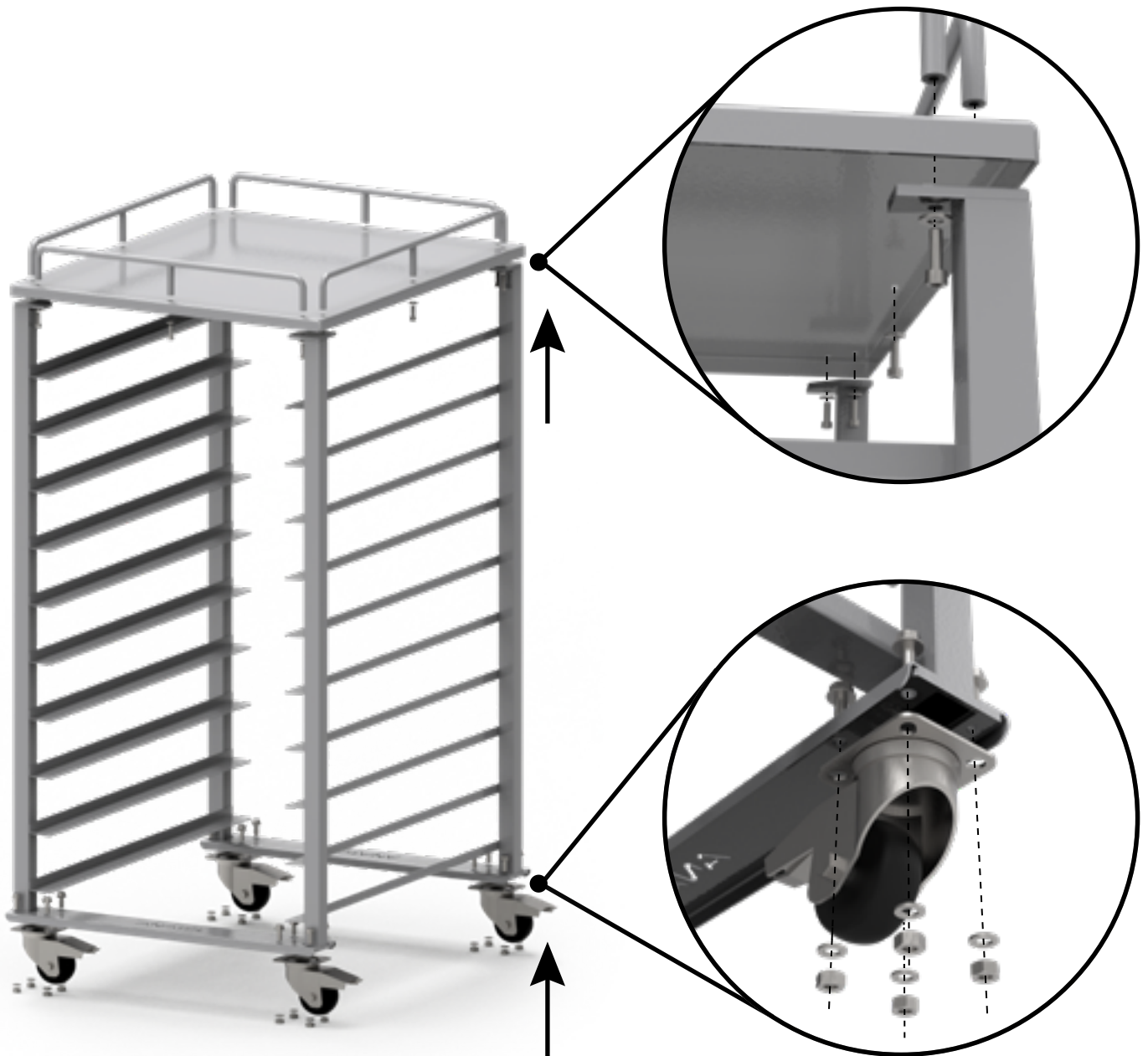
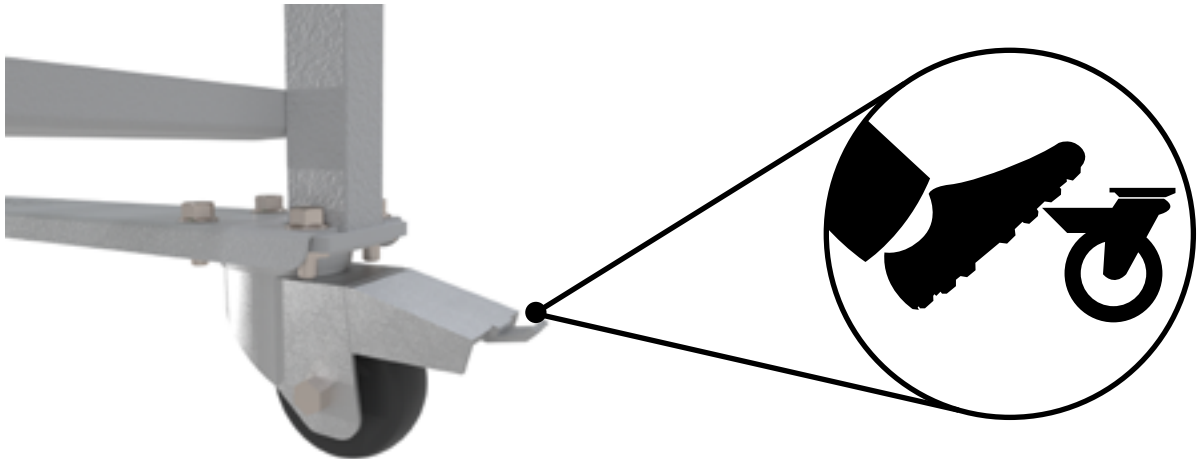

Fig. 1

2. Install the lower crossbars (2) and wheels (4) on the shelf walls (1) and attach using the bolts (5) washer (9) and nuts (6).

3. When you have moved the Ink Cart to its desired location, the wheels should be locked using the brake.



4. The Ink Cart is designed for storing screens for screen printing, ink containers and auxiliary supplies and inventory. For safety reasons, it is forbidden to use the Ink Cart for anything other than its intended purpose.

